



PIONEERING ENVIRONMENTAL SUSTAINABILITY

NEW

SC-1 SELF-CONTAINED CONCRETE WASH-OUT STATION

The PumperDump™ SC-1 CONCRETE WASH-OUT STATION is a cost-effective on-site solution to the many problems of concrete washouts.

Able to cope with both large and small projects, the PumperDump SC-1 improves pumping efficiency by providing a self-contained washout facility.

An internal closed-loop recycling process reuses all washout water, and the solid concrete waste is separated out for removal or use on site.



PREVENTS WATER CONTAMINATION

The PumperDump System prevents rainwater and groundwater contamination throughout the building process through its wastewater recycling technology.

WHEN TO USE IT

The PumperDump SC-1 self-contained unit has been designed for use at larger building and construction sites where extra space is available. Other PumperDump solutions are available for smaller sites.

The hopper will service up to 30 concrete mixer trucks and a concrete pump. No access ramp is required and the unit can be used by two trucks at the same time.

HOW IT WORKS

The self-contained PumperDump SC-1 unit is delivered direct to your site. The SC-1 unit has a generator for power or can use mains power.

The unit consists of five components: hinged and locked hopper, walkway, a pumping system, a forced weir tank system, and a control box.

The closed-loop system captures the concrete waste water in the hinged hopper. The pumping system then collects the water from under the hopper and forces it into the weir tank system for separation and filtration. Recycled water is stored in the weir system for reuse.

Once dry, the concrete waste in the hopper can be emptied and then broken up and used on site, or removed by PumperDump.



PumperDump™
RECYCLING CONCRETE WASH-OUT

telephone 1300 366 668 email inquiries@pumperdump.com website www.pumperdump.com



PIONEERING ENVIRONMENTAL SUSTAINABILITY

NEW

SC-1 SELF-CONTAINED CONCRETE WASH-OUT STATION

SERVICE & MAINTENANCE

PumperDump™ delivers the unit and provides on-the-spot training. The unit is very low maintenance, but service is provided if needed.

MULTIPLE BENEFITS

- Maximises pumping time
- Cost-effective
- Water conservation
- Solves washouts problems
- Exceeds EPA standards
- Meets OH&S guidelines
- Simple operation: minimal training
- Mains or generator power
- Proven technology

SC-1 SPECIFICATIONS

The size of the PumperDump SC-1 unit is 4.7m by 2.0m and 0.86m high. The concrete hopper has a capacity of 0.8m³. It weighs approximately 3.2 tonnes empty and 5.5 tonnes full.

The PumperDump SC-1 unit runs off mains power, or may be powered from its own on-board generator.

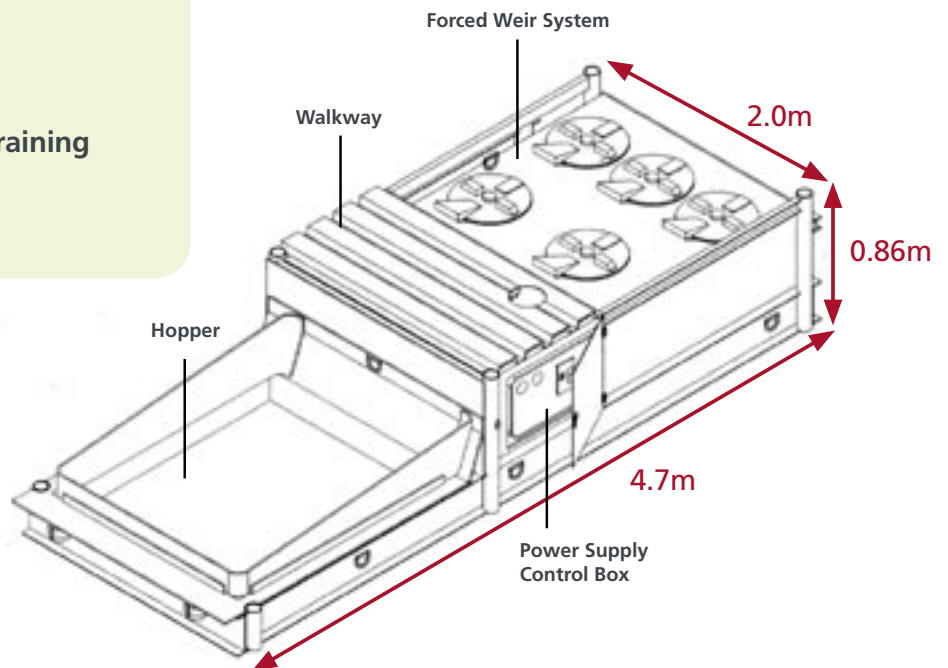

PumperDump™
RECYCLING CONCRETE WASH-OUT